

ProCharger Supercharger Serpentine Kits for LSx Engines



LS TRANSPLANT SERPENTINE KITS (EFI AND CARBURETED)

Year	Part Number	Description	Boost Options	HP Gain	Std Intercooler	MSRP
call	1LS100-P1SC1	High Output with P-1SC-1	call	call	-	\$3,696
call	1LS100-P1SC1I	High Output with Intercooled P-1SC-1	call	call	2 core (550 hp)	\$4,496
call	1LS100-DISC	High Output with D-1SC	call	call	-	\$3,926
call	1LS100-DISCI	High Output with Intercooled D-1SC	call	call	3 core (825 hp)	\$5,096
call	1LS100-F1	High Output with F-1D / F-1 / F-1A	call	call	-	\$4,896
call	1LS100-F1I	High Output with Intercooled F-1D / F-1 / F-1A	call	call	Sht mtl 3C (950 hp)	\$6,096
call	1LS100-F1R	High Output with F-1C / F-1R	call	call	-	\$5,246
call	1LS100-F1RI	High Output with Intercooled F-1C / F-1R	call	call	Sht mtl 3C (1050 hp)	\$6,546

LS TRANSPLANT KIT OPTIONS	add "-P" to part #	Polished finish for ProCharger (9" housing)	head unit only, satin std.	-	-	+\$250
	add "-P" to part #	Polished finish for ProCharger (9.75" housing)	head unit only, satin std.	-	-	+\$275
	add "-P" to part #	Polished finish for ProCharger (10.5" housing)	head unit only, satin std.	-	-	+\$300
	add "-B" to part #	Polishing of main bracket(s) and tensioner	satin finish std	-	-	+\$180
	add "-C" to part #	Polished finish for carburetor bonnet	satin finish std	-	-	+\$90
	add "-12R" to part #	12 Rib drive system upgrade (from 8 Rib, Serp Kits only)	-	-	-	\$152
	AM006A-001	Low Profile Carb Bonnet (3" inlet, 2" height)	satin finish std	-	-	\$159
	AM009A-001	Standard Carb Bonnet (3.5" inlet, 2.75" height)	satin finish std	-	-	\$199
	AM001A-001	Competition Carb Bonnet (3.5" inlet, 4.15" height)	satin finish std	-	-	\$219
	call	Non-intercooled carb tubing kit (3" or 3.5")	-	-	-	call
	add "-H" to part #	Helical gearset for noise reduction (P-1SC-1, D-1SC)	same	same	-	+\$100
	3LSAT-001	Alternator bracket (requires GM tensioner, #12569301)	-	-	-	+\$325
	3LSPS-001	Power steering bracket (requires GM pump, #15261472)	-	-	-	+\$229
	3LSPS-002	Power steering delete bracket	-	-	-	+\$152
	AI003A-001	3 core intercooler (825 hp)	from non-ic kit	3" in/outlet	-	+\$962
	AI003A-002	Sheet metal 3 core race intercooler (950 hp)	from non-ic kit	3" in/outlet	-	+\$1170
	AI003A-005	Sheet metal 3 core race intercooler (1050 hp)	from non-ic kit	3.5" in/outlet	-	+\$1222
	AI045A-001	Sheet metal 3 core race intercooler (1300 hp)	from non-ic kit	3.5" in/outlet	-	+\$1586
	AI006A-001	Sheet metal 3 core race intercooler (1550 hp)	from non-ic kit	4" in/outlet	-	+\$1924
	3CASS-002	ProFlo bypass valve kit	-	-	-	+\$224
	AV006A-003	Bullet bypass valve kit	-	-	-	+\$291
	3FASS-00X	Race bypass valve open (specify aluminum or steel flange)	-	-	-	+\$415
3FASS-00X	Race bypass valve closed (specify aluminum or steel flange)	-	-	-	+\$415	
FP001I-006	High Performance 1000 hp electric fuel pump	-	-	-	+\$332	
3GKMM-004	Crank Pin Kit	-	-	-	+\$99	

SEE REVERSE SIDE FOR DIMENSIONS



ProCharger Supercharger Serpentine Kits for LSx Engines

KIT DIMENSIONS

AVAILABLE OPTIONS

- Alternator bracket
- Power steering bracket
- Power steering delete bracket
- Bullet bypass valve kit
- High performance 1,000 hp electric fuel pump
- Crank Pin Kit
- Low profile carb bonnet
- Standard carb bonnet
- Competition carb bonnet
- 12-Rib Upgrade
- Polished finish (ProCharger, bracket and carb bonnet)

LSx FOOTNOTES

- 1) 1966-72 A body (Chevelle, GTO, ect.)
1968-72 Nova
1968-81 Camaro/Firebird
Fitment into the listed vehicles confirmed. Variability of chassis and aftermarket components may require modifications
- 2) Specify with or without power steering when using ProCharger Accessory Brackets; NAPA power steering pump #81-1373 (or others), (sold separately by others)
- 3) Alternator bracket compatible with: NAPA alternator: #AL8800X (or others), (sold separately by others)
- 4) Belt Tensioner compatible with: NAPA tensioner: #38195 (or others), (sold separately by others)
- 5) Compatible with: GM A/C bracket: #92066950; NAPA A/C compressor: #67288;
GM A/C belt: #25-040430; NAPA A/C belt tensioner: #38196 (or others), (sold separately by others)
- 6) Pinning of the crank pulley is recommended
- 7) Compatible with mechanical or electric water pump
- 8) Designed to work with Muscle Rods motor mounts (application dependent) (or others), (sold separately by others)
- 9) Intercooled kits contain "universal components", customization required

Note: Factory-style EFI intake shown; Serpentine Drive Supercharger Kits are compatible with aftermarket EFI or carburetor-equipped LSx engines

*Additional ProCharger LS brackets available – Call for options

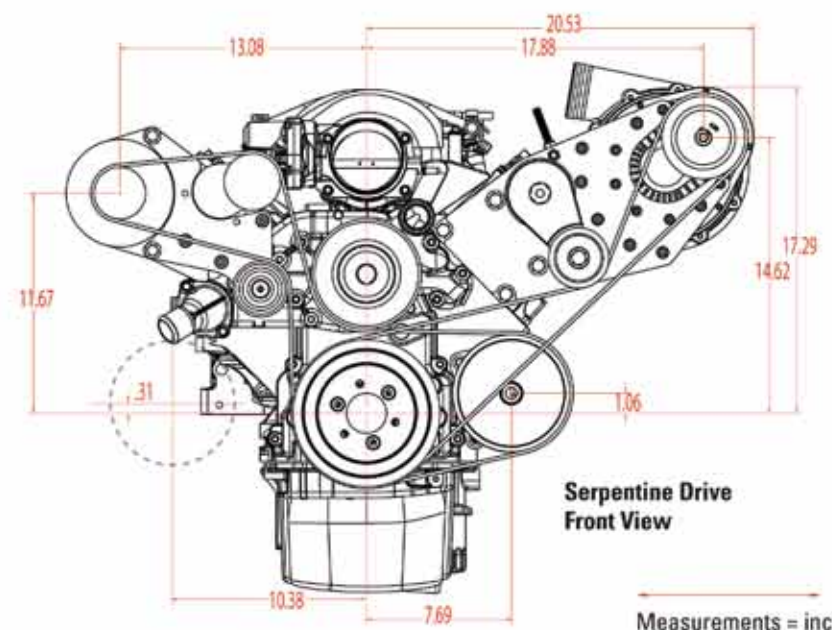
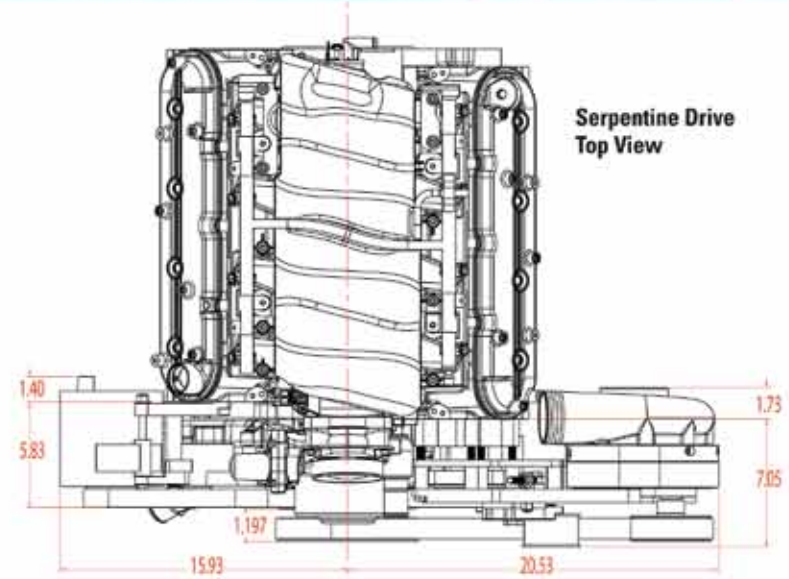

Measurements = inches



SEE REVERSE SIDE FOR PRICING